

MY True miles Quick Installation Guide

MTM110 Series

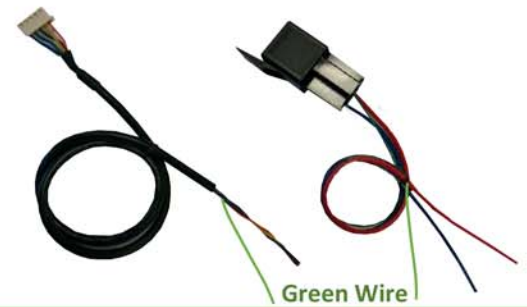

Optional SID Relay and I/O Cable



MTM 110 Series Installation Steps

How to Hard Wire your GPS Tracking Unit

Your GPS tracking device comes with a wiring harness. All electronics and antennas are internal to the device. Tools you may use to perform the installation include: Screwdrivers, Wire strippers and cutters, Crimping tool, Voltmeter. Additional materials you might use: Connectors, Tape, Zip Ties

For basic operation, connections are required to constant Power (+12V) and to Ground (sometimes called negative). It is very important to ensure that your installation will last through the use of the vehicle. The environment inside a vehicle is harsh due to vibration, temperature extremes, corrosion, humidity, and unexpected events. **The primary cause of failure for vehicle tracking devices is the unexpected disconnection of the power or ground wires.**

1) Connecting Constant +12V Power (Red wire)

First, use the multi-meter to find a source of CONSTANT +12V near the dashboard of the car. There are multiple places where this can be found, and the locations vary between vehicles. Some locations are more discreet than others, so plan your installation according to your needs. You may find specific wiring details for your vehicle on the internet to assist in locating the wires you need. For example, <http://www.the12volt.com/> is one such source.

Ensure that the wire you choose is a CONSTANT source of +12V. The multi-meter should show approximately 12V between your source and chassis ground regardless of the Ignition Switch position, and whether doors are open or closed, lights or other accessories are on or off, etc.

Using your preferred connector type, or solder, connect the RED wire from the tracker to the source of +12V. Be sure not to permanently disconnect the 12V source to other circuits in the vehicle and take care to make a strong connection to survive vibration and temperatures.

2) Connecting Ground (Black wire)

The black wire must be connected to a source of chassis ground. This can be either another grounded wire, or a clean metal connection to the chassis of the vehicle. Be sure not to permanently interrupt the ground connection to any other circuit in the vehicle and that you have a strong and clean connection.

Testing The Installation

Test the installation by turning the car on and off, opening and closing the driver's door, and turning lights and dome lights on and off. Constant power should not be interrupted by these actions, and the device should continue to operate as you can tell by looking at the lights.

Verify LED Status



Color	Function	What to Look For
Orange	Cellular Network	Blinking = Searching Solid = Cellular signal is OK
Green	GPS Network	Blinking = Searching Solid = GPS Signal is OK

Starter Interrupt (SID) Installation *Optional*

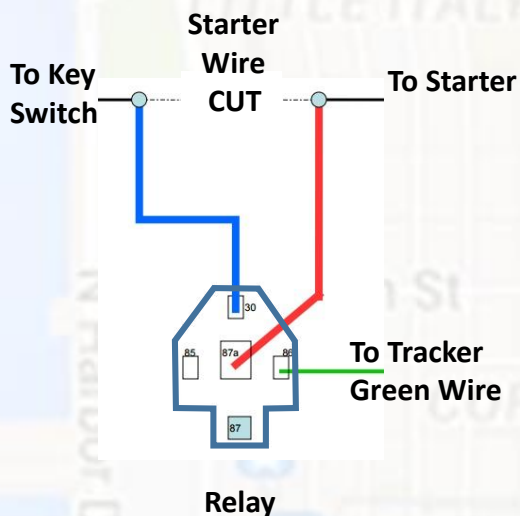

1. With a Voltmeter, find the wire from the key that activates the starter.
2. This link may help you identify the correct wire for different vehicles <http://www.commandocaralarms.com/wiringsearch.asp>
3. Cut the wire, and connect the **Blue** wire from the SID to the end which goes toward the key. It should show about 12V when the key is on Start, but 0V otherwise.
4. Connect the **Red** wire from the SID to the other cut end of the Ignition wire.
5. Connect the Green wire from the SID to the Green wire from the Tracker. There are a number of videos and guides on the internet, but note that relays come with many different colors of wires. You should go by the position in the relay socket, not just the color of the wire.

Tracker Mounting Guidelines

The GPS device is intended to be inside the cabin of a vehicle, and is not waterproof. It is not designed to be mounted externally or under the hood of a vehicle. The GPS device contains internal Cellular and GPS antennas, so the location and orientation of the device is important for reliable tracking. The location should be somewhere such that no metal is between the device and the sky. A typical location is under a plastic dashboard in the area under the windshield.

You can mount the device using zip ties, strong double sided tape, or similar items. **Mount it with the label facing down**, because the antenna is on this side. Conceal and secure the wires of the harness, and trim or bundle up unused wires. Make sure that wires can't fall into visible areas of the vehicle and be tugged. Make sure that they are not in locations where they may be damaged by the operation of pedals, glove boxes, fans, heaters, etc.