MTM1400 SERIES - INSTALLATION GUIDE

HOW TO HARD WIRE YOUR GPS TRACKING UNIT

Your GPS tracking device comes with a wiring harness. All electronics and antennas are internal to the device. Tools you may use to perform the installation include: Screwdrivers, Wire strippers and cutters, Crimping tool, Voltmeter. Additional materials you might use: Connectors, Tape, Zip Ties

For basic operation, connections are required to constant Power (+12V) and to Ground (sometimes called negative). It is very important to ensure that your installation will last through the use of the vehicle. The environment inside a vehicle is harsh due to vibration, temperature extremes, corrosion, humidity, and unexpected events. **The primary cause of failure for vehicle tracking devices is the unexpected disconnection of the power or ground wires**

1) Connecting Constant +12V Power (Red wire)

First, use the multi-meter to find a source of CONSTANT +12V near the dashboard of the car. There are multiple places where this can be found, and the locations vary between vehicles. Some locations are more discreet than others, so plan your installation according to your needs. You may find specific wiring details for your vehicle on the internet to assist in locating the wires you need. For example, <http://www.the12volt.com/> is one such source.

Ensure that the wire you choose is a CONSTANT source of +12V. The multi-meter should show approximately 12V between your source and chassis ground regardless of the Ignition Switch position, and whether doors are open or closed, lights or other accessories are on or off, etc.

Using your preferred connector type, or solder, connect the **RED** wire from the tracker to the source of +12V. Be sure not to permanently disconnect the 12V source to other circuits in the vehicle and take care to make a strong connection to survive vibration and temperatures

2) Connecting Ground (Black wire)

The **BLACK** wire must be connected to a source of chassis ground. This can be either another grounded wire, or a clean metal connection to the chassis of the vehicle. Be sure not to permanently interrupt the ground connection to any other circuit in the vehicle and that you have a strong and clean connection

GREEN and WHITE Wires

The cable provided with each 1400 device also has green and white wires that for most regular installations will not be used. For starter interrupt relay installations the green wire is used connecting the device to the relay (ref diagram below). For special applications the white wire can be used for ignition sense.

TESTING THE INSTALLATION

Test the installation by turning the vehicle on and off, opening and closing the driver's door, and turning lights and dome lights on and off. Constant power should not be interrupted by these actions, and the device should continue to operate as you can tell by looking at the lights.



MTM1400



My True Miles, LLC



Phone
1.800.434.1101



Email
info@mytruemiles.com



Website
www.mtmgps.com



MTM1400



COLOR	FUNCTION	WHAT TO LOOK FOR
Orange	Cellular Network	Blinking = Searching Solid = Cellular signal is OK
Green	GPS Network	Blinking = Searching Solid = GPS Singal is OK

STARTER INTERRUPT (SID) INSTALLATION (OPTIONAL)

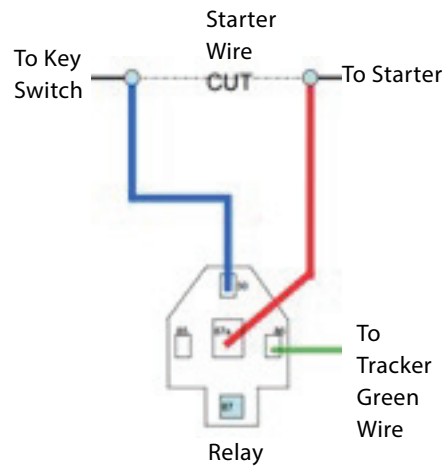

1. With a Voltmeter, find the wire from the key that activates the starter.

2. This link may help you identify the correct wire for dilereent vehicles: www.bulldogsecurity.com/bdnew/vehiclewiringdiagrams.aspx.

3. Cut the wire and connect the BLUE wire from the SID to the end, which goes toward the key. It should show about 12V when the key is on Start, but OV otherwise.

4. Connect the RED wire from the SID to the other cut end of the Ignition wire.

5. Connect the GREEN wire from the SID to the Green wire from the tracker. There are a number of videos and guides on the internet, but note that the relays come with many dilereent colors of wires. You should go by the position in the relay socket, not just the color of the wire.

LED SLEEP BEHAVIOR

When sleeping, the LEDS on the 1400 device go dark, except for a momentary flash of the green LED every several seconds. The device wakes up to vibration/movement by an increase in input voltage detected on the RED wire, or by input 0 (the ignition input/WHITE wire) going from LOW to HIGH.

When the device wakes, both LEDs will flash for several moments as the device connects to the cell network and obtains a GPS fix. At wake up, the standard LED patterns go into effect.

The 1400 series devices are programmed by default to enter sleep mode 5 minutes after no movement or changes in input voltage is detected. This means that the device could enter sleep mode during installation. To wake device(s), shake for about 10 seconds if it enters sleep mode

TRACKER MOUNTING GUIDELINES

The GPS 1400 device is intended to be inside the cabin of a vehicle, and is not waterproof. The GPS device contains internal Cellular and GPS antennas, so the location and orientation of the device is important for reliable tracking. The location should be somewhere such that no metal is between the device and the sky. A typical location is under a plastic dashboard in the area under the windshield.

You can mount the device using zip ties, strong double sided tape, or similar items. Mount it with the label facing down, because the antenna is on this side. Conceal and secure the wires of the harness, and trim or bundle up unused wires. Make sure that wires can't fall into visible areas of the vehicle and be tugged. Make sure that they are not in locations where they may be damaged by the operation of pedals, glove boxes, fans, heaters, etc.



My True Miles, LLC



Phone

1.800.434.1101



Email

info@mytruemiles.com



Website

www.mtmgps.com